

# MS4N1350 MS4N1350E MS4N1350B MS4N1350W MS4N1350S

N-channel 1500 V, 6  $\Omega$ , 4 A, Power MOSFET  
in TO-263, TO-247, TO-220F, TO-3PB, TO-3PH

## Features

Type	V <sub>DSS</sub>	R <sub>DS(on)</sub>	I <sub>D</sub>	P <sub>TOT</sub>
		max.		
MS4N1350S	1500 V	< 9 $\Omega$	4 A	63 W
MS4N1350	1500 V	< 9 $\Omega$	4 A	140 W
MS4N1350B	1500 V	< 9 $\Omega$	4 A	140 W
MS4N1350E	1500 V	< 9 $\Omega$	4 A	80 W
MS4N1350W	1500 V	< 9 $\Omega$	4 A	140 W

- 100% avalanche tested
- Intrinsic capacitances and Q<sub>g</sub> minimized
- High speed switching

## Application

Switching applications

## Description

MasPower has designed an advanced family of very high voltage Power MOSFETs with outstanding performances. The strengthened layout coupled with the company's proprietary edge termination structure, gives the lowest R<sub>DS(on)</sub> per area, unrivalled gate charge and switching characteristics.

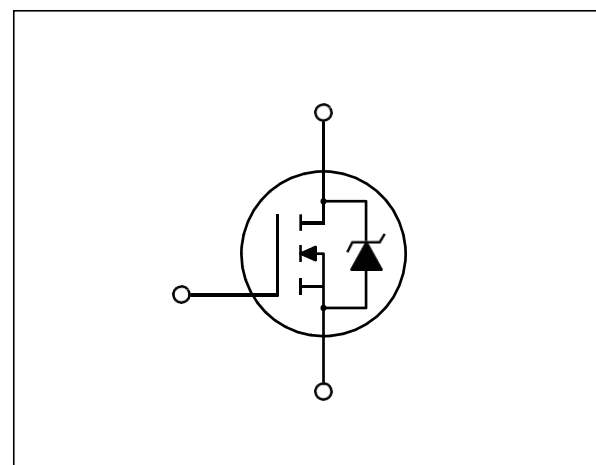
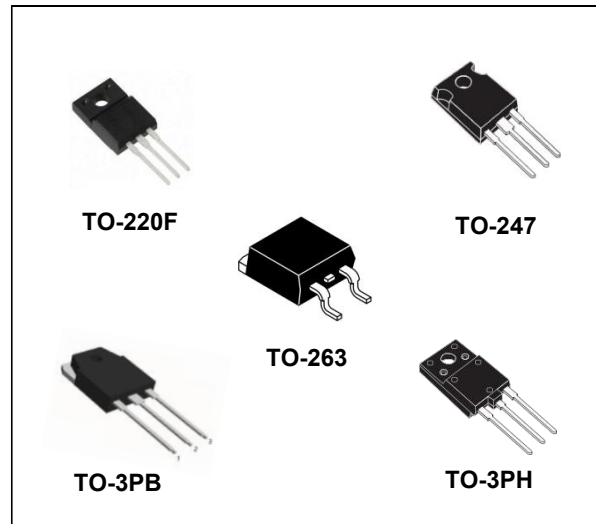

Table 1. Device summary

Order codes	Marking	Package	Packaging
MS4N1350	MS4N1350	TO-3PH	Tube
MS4N1350S	MS4N1350S	TO-220F	Tube
MS4N1350E	MS4N1350E	TO-263	Tube
MS4N1350B	MS4N1350B	TO-3PB	Tube
MS4N1350W	MS4N1350W	TO-247	Tube

# 1 Electrical ratings

**Table 2. Absolute maximum ratings**

Symbol	Parameter	Value		Unit
		TO-3P,TO-3PH,TO-247	TO-220F	
$V_{DS}$	Drain-source voltage ( $V_{GS} = 0$ )	1500		V
$V_{GS}$	Gate-source voltage	$\pm 30$		V
$I_D$	Drain current (continuous) at $T_C = 25\text{ }^\circ\text{C}$	4	4 <sup>(1)</sup>	A
$I_D$	Drain current (continuous) at $T_C = 100\text{ }^\circ\text{C}$	2.6	2.6 <sup>(1)</sup>	A
$I_{DM}$ (1)	Drain current (pulsed)	10	10 <sup>(1)</sup>	A
$P_{TOT}$	Total dissipation at $T_C = 25\text{ }^\circ\text{C}$	140	63	W
$V_{ISO}$	Insulation with stand voltage (RMS) from all three leads to external heat sink ( $t=1\text{ s}; T_C=25\text{ }^\circ\text{C}$ )		3500	V
	Derating factor	1.18	0.63	W/°C
$T_{stg}$	storage temperature	-50 to 150		°C
$T_j$	Max. operating junction temperature	150		°C

1. Pulse width limited by safe operating area

**Table 3. Thermal data**

Symbol	Parameter	TO-3P	TO-247	TO-263	TO-3PH,TO-220F	Unit
$R_{thj-case}$	Thermal resistance junction-case max	0.9		0.63	2	°C/W
$R_{thj-amb}$	Thermal resistance junction-ambient max	63.5	50	35	50	°C/W
$T_j$	Maximum lead temperature for soldering purpose	300				°C

**Table 4. Avalanche characteristics**

Symbol	Parameter	Max value	Unit
$I_{AR}$	Avalanche current, repetitive or not-repetitive (pulse width limited by $T_j$ max)	4	A
$E_{AS}$	Single pulse avalanche energy (starting $T_j = 25\text{ }^\circ\text{C}$ , $I_D = I_{AR}$ , $V_{DD} = 50\text{ V}$ )	510	mJ

## 2 Electrical characteristics ( $T_{\text{case}} = 25\text{ °C}$ unless otherwise specified)

**Table 5. On /off states**

Symbol	Parameter	Testconditions	Min.	Typ.	Max.	Unit
$V_{(BR)DSS}$	Drain-source breakdown voltage	$I_D = 1\text{ mA}$ , $V_{GS} = 0$	1500			V
$I_{DSS}$	Zero gate voltage	$V_{DS} = \text{Max rating}$			10	$\mu\text{A}$
	drain current ( $V = 0$ )	$V = \text{Max rating}$ , $T = 125\text{ °C}$			500	$\mu\text{A}$
$I_{GSS}$	Gate-body leakage current ( $V_{DS} = 0$ )	$V_{GS} = \pm 30\text{ V}$			$\pm 100$	nA
$V_{GS(th)}$	Gate threshold voltage	$V_{DS} = V_{GS}$ , $I_D = 250\text{ }\mu\text{A}$	3.2	4.5	6	V
$R_{DS(on)}$	static drain-source on resistance	$V_{GS} = 10\text{ V}$ , $I_D = 1.3\text{ A}$		5.8	9	$\Omega$

**Table 6. Dynamic**

Symbol	Parameter	Test conditions	Min.	Typ.	Max.	Unit
$g_{fs}$ (1)	Forward transconductance	$V_{DS} = 30\text{ V}$ , $I_D = 1.3\text{ A}$	-	2.6	-	S
$C_{iss}$	Input capacitance	$V_{DS} = 25\text{ V}$ , $f = 1\text{ MHz}$ , $V_{GS} = 0$	-	1408	-	$\mu\text{F}$
$C_{oss}$	Output capacitance			153		$\mu\text{F}$
$C_{rss}$	Reverse transfer capacitance			19.8		$\mu\text{F}$
$C_{oss\text{ eq.}}$ (2)	Equivalent output capacitance	$V_{DS}=0$ to $1200\text{ V}$ , $V_{GS} = 0$	-	138	-	$\mu\text{F}$
$R_g$	Gate input resistance	$f=1\text{ MHz}$ Gate DC Bias=0 Test signal level=20 mV open drain	-	5.3	-	$\Omega$
$Q_g$	Total gate charge	$V_{DD} = 1200\text{ V}$ , $I_D = 4\text{ A}$ , $V_{GS} = 10\text{ V}$ <i>(see Figure 19)</i>	-	44	-	nC
$Q_{gs}$	Gate-source charge			6.9		nC
$Q_{gd}$	Gate-drain charge			23.8		nC

1. Pulsed: Pulse duration = 300  $\mu\text{s}$ , duty cycle 1.5%
2.  $C_{oss\text{ eq.}}$  is defined as a constant equivalent capacitance giving the same charging time as  $C_{oss}$  when  $V_{DS}$  increases from 0 to 80%  $V_{DSS}$

**Table 7. Switching times**

Symbol	Parameter	Test conditions	Min.	Typ.	Max.	Unit
$t_{d(on)}$	Turn-on delay time	V = 800 V, I = 1.25 A, R <sub>G</sub> = 4.8 Ω, V <sub>GS</sub> = 10 V		26		ns
$t_r$	Rise time			51		ns
$t_{d(off)}$	Turn-off-delay time		-	48	-	ns
$t_f$	Fall time			69		ns

**Table 8. Source drain diode**

Symbol	Parameter	Test conditions	Min.	Typ.	Max.	Unit
I <sub>SD</sub>	Source-drain current				4	A
I <sub>SDM</sub> (1)	Source-drain current (pulsed)		-		10	A
V <sub>SD</sub> (2)	Forward on voltage	I <sub>SD</sub> = 4 A, V <sub>GS</sub> = 0	-		1.63	V
$t_{rr}$	Reverse recovery time	I <sub>SD</sub> = 4 A, di/dt = 100 A/μs V <sub>DD</sub> = 60 V		390		ns
Q <sub>rr</sub>	Reverse recovery charge			2.2		μc
I <sub>RRM</sub>	Reverse recovery current		-	12.6		A
$t_{rr}$	Reverse recovery time	I <sub>SD</sub> = 4 A, di/dt = 100 A/μs V <sub>DD</sub> = 60 V, T <sub>j</sub> = 150 °C		510		ns
Q <sub>rr</sub>	Reverse recovery charge			3.8		μc
I <sub>RRM</sub>	Reverse recovery current		-	13.2		A

1. Pulse width limited by safe operating area
2. Pulsed: pulse duration = 300 μs, duty cycle 1.5%

## 2.1 Electrical characteristics (curves)

Figure 2. Safe operating area for TO-3PH

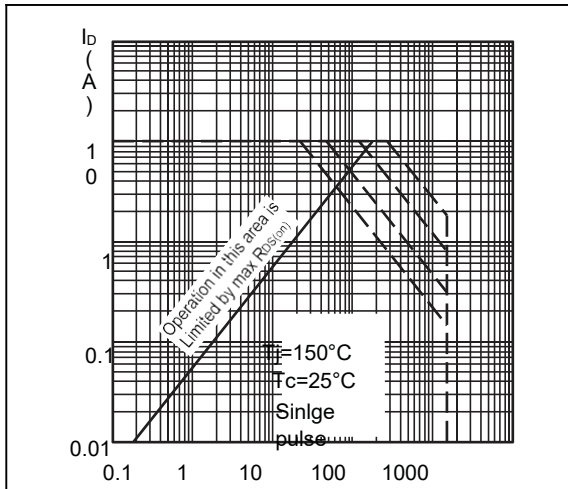

Figure 3. Thermal impedance for TO-3PH

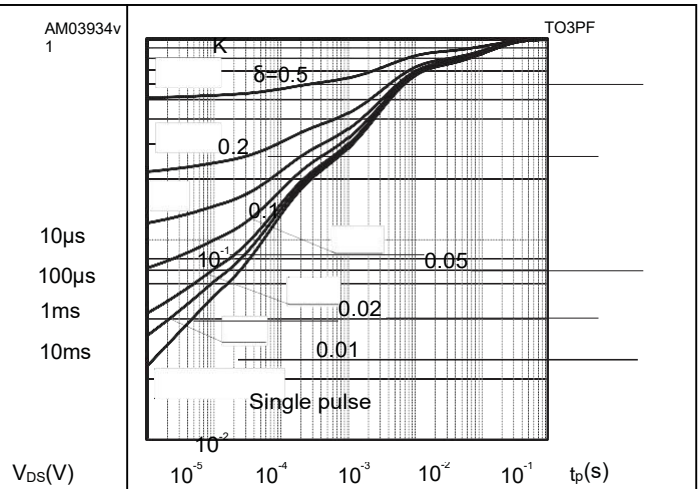

Figure 4. Safe operating area for TO-220

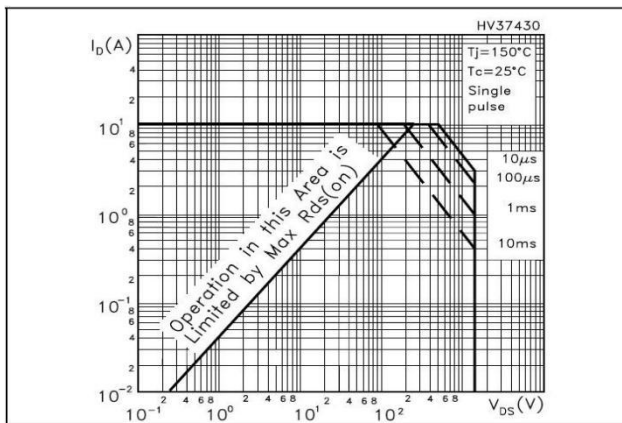

Figure 5. Thermal impedance for TO-220

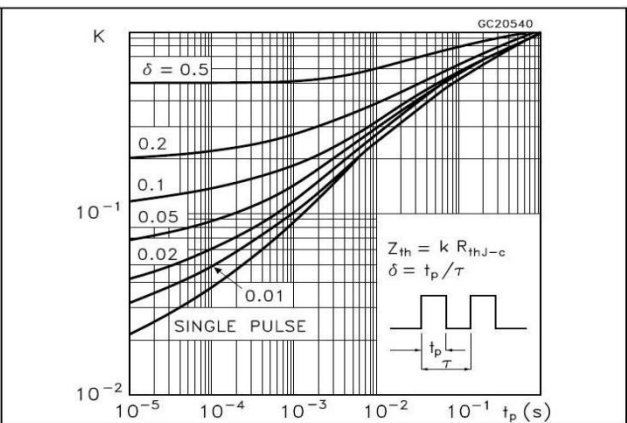

Figure 6. Safe operating area for TO-247

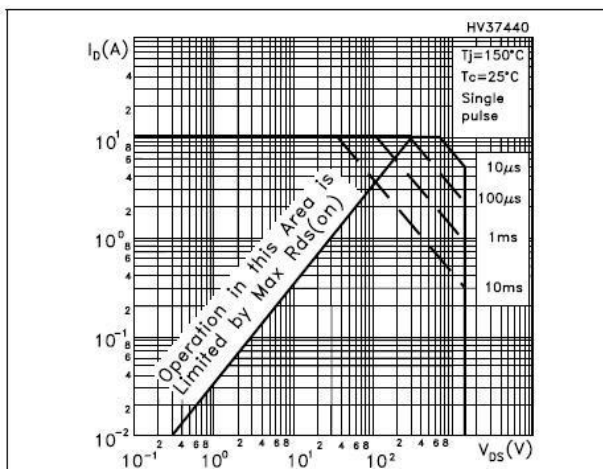

Figure 7. Thermal impedance for TO-247

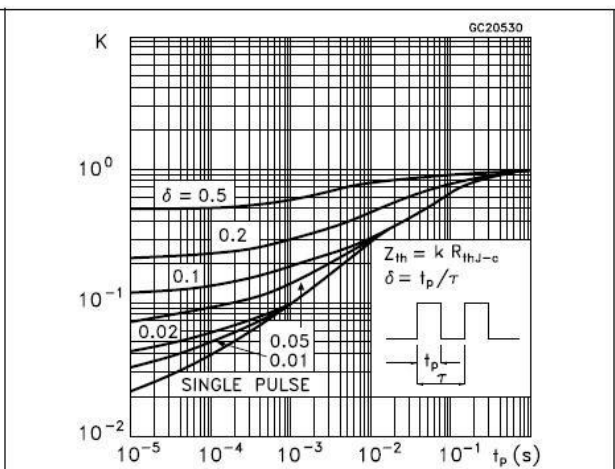

Figure 8. Output characteristics

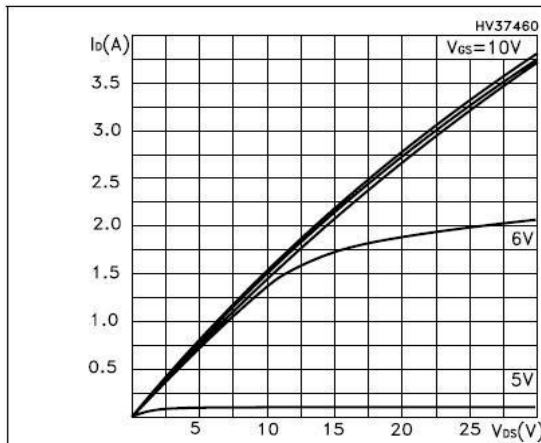

Figure 9. Transfer characteristics

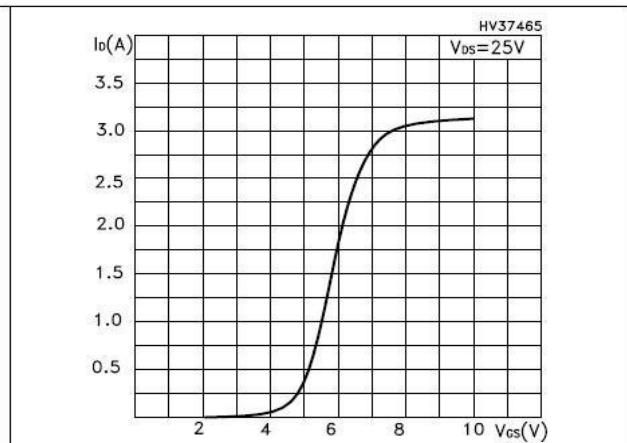

Figure 10. Normalized  $BV_{DSS}$  vs. temperature

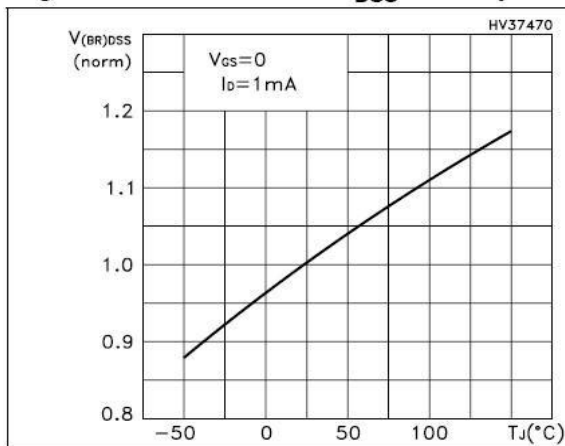

Figure 11. Static drain-source on resistance

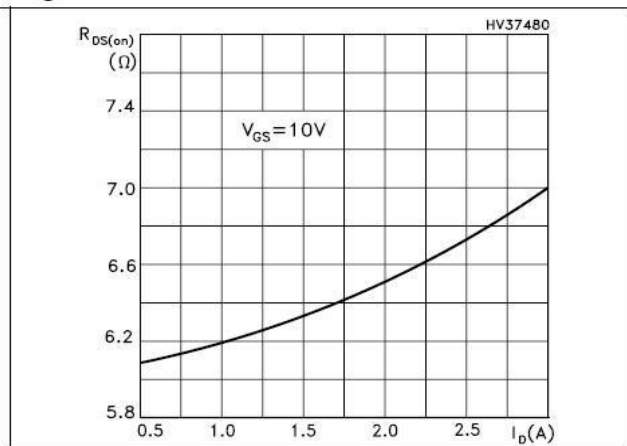

Figure 12. Gate charge vs. gate-source voltage

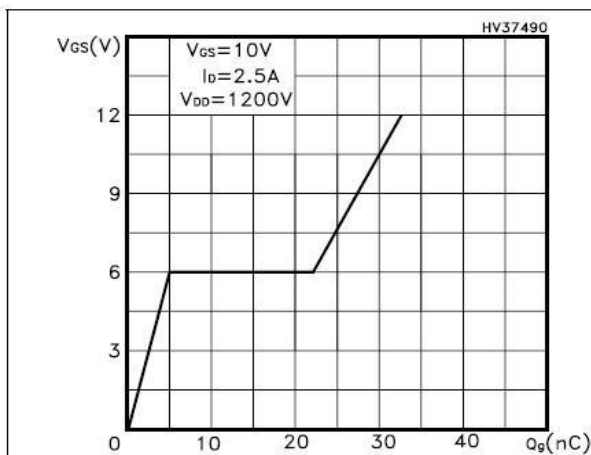

Figure 13. Capacitance variations

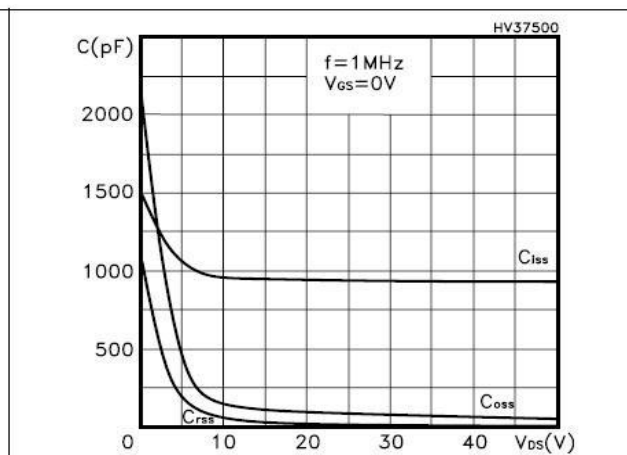

Figure 14. Normalized gate threshold voltage vs. temperature

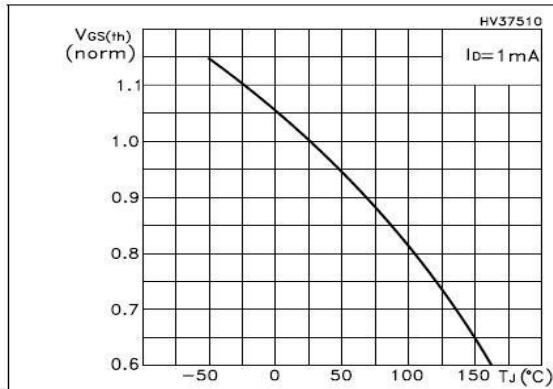

Figure 15. Normalized on resistance vs. temperature

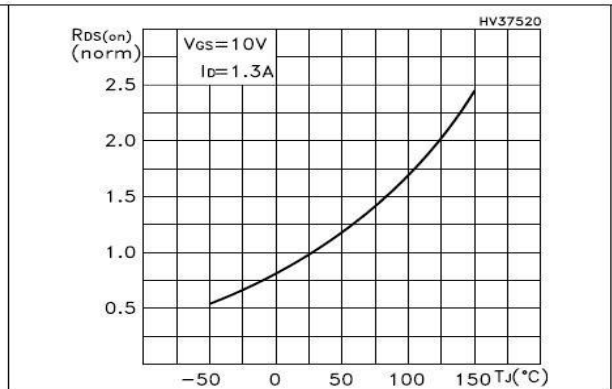

Figure 16. Source-drain diode forward characteristics

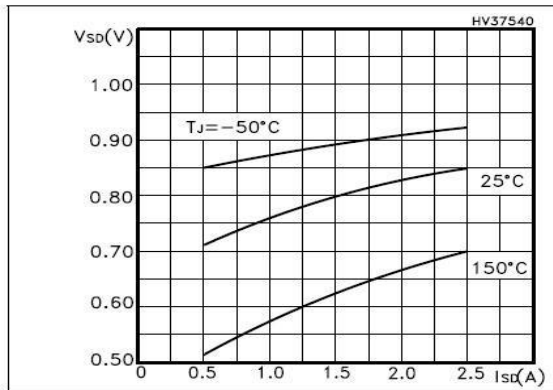
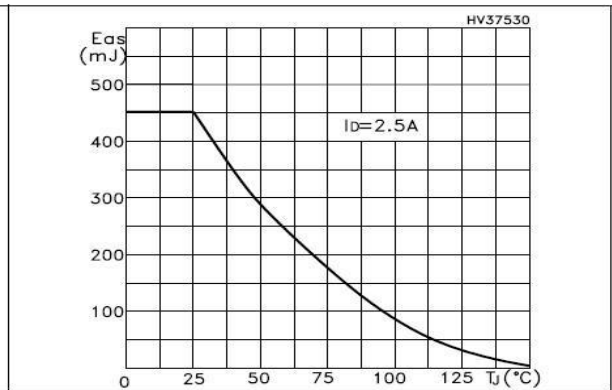

Figure 17. Maximum avalanche energy vs Tj



### 3 Test circuits

Figure 18. Switching times test circuit for resistive load

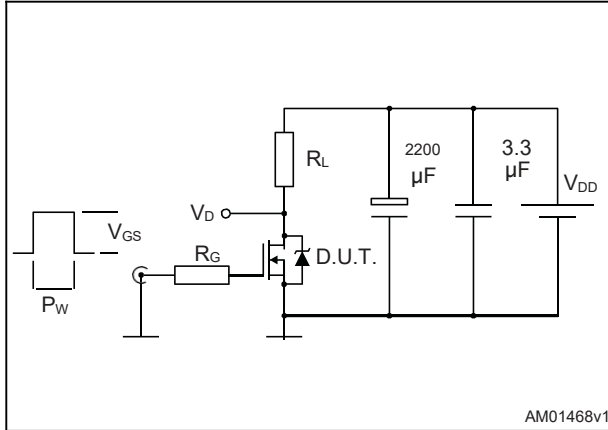

Figure 19. Gate charge test circuit

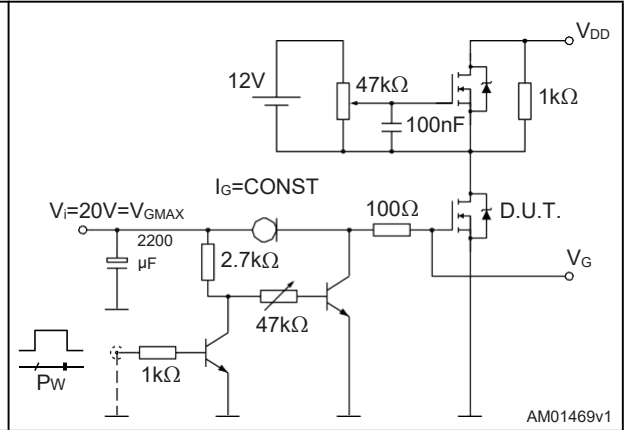

Figure 20. Test circuit for inductive load switching and diode recovery times

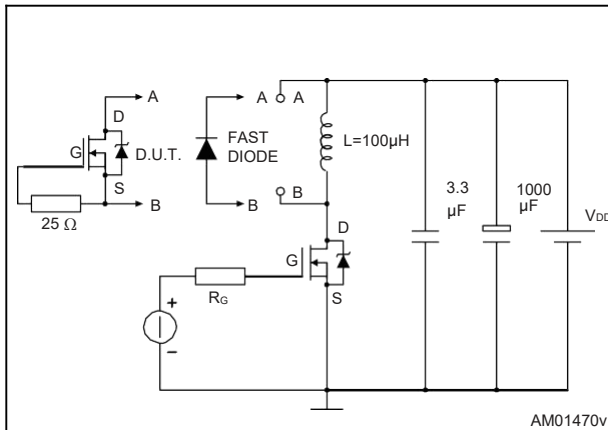

Figure 21. Unclamped inductive load test circuit

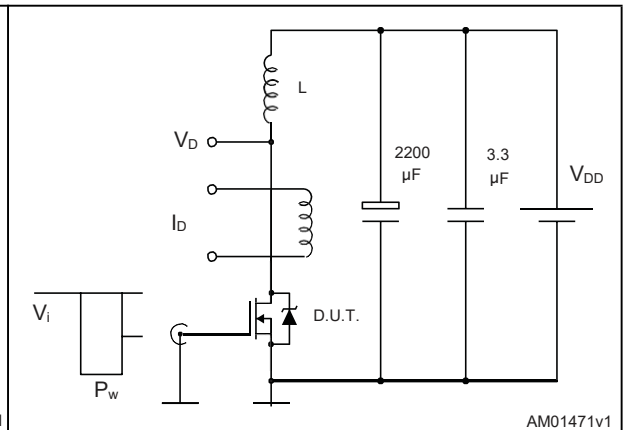

Figure 22. Unclamped inductive waveform

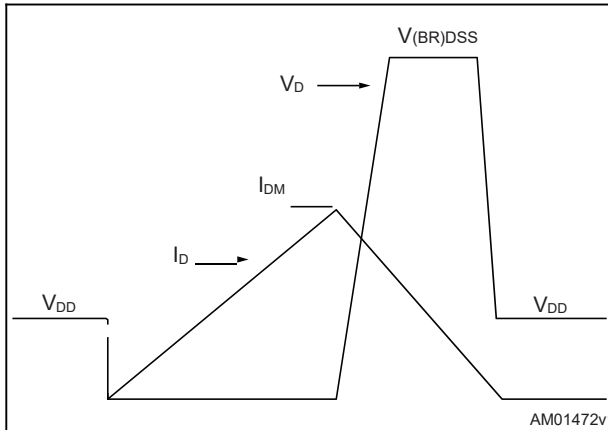
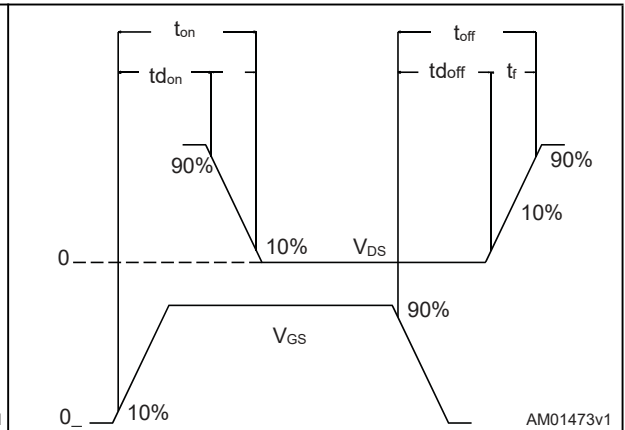

Figure 23. Switching time waveform





## 4 Package mechanical data

TO-220F mechanical

DIM.	mm.		
	min.	typ	max.
A	4.52		4.82
C	0.45		0.6
D	15.67		15.97
Q1	3.20		3.41
E	10.01		10.36
F	2.34		2.74
L	12.78		13.18
G	6.48		6.88
L1	3.23		3.43
R		3.18	

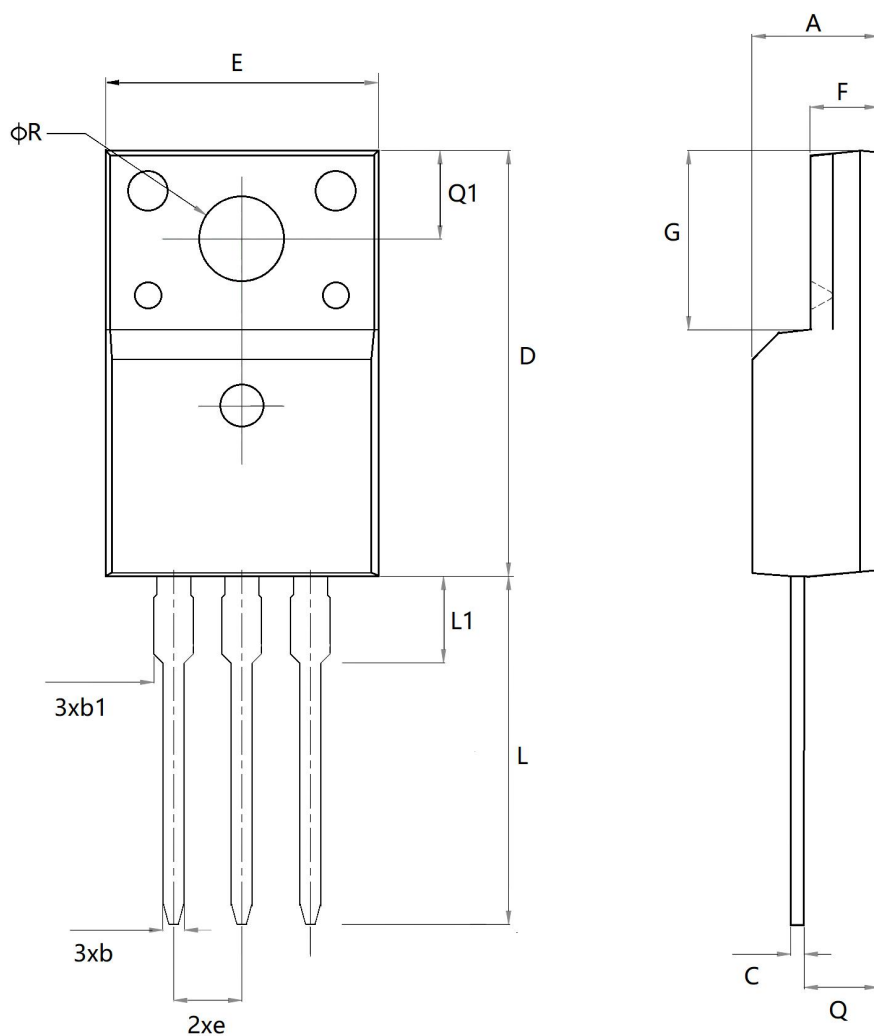

Package mechanical data

**TO-3PB Mechanical data**

Dim	mm.		
	Min	Typ	Max
A	15.3	15.6	15.9
A1	13.8	14	14.2
b	2.4	2.6	2.8
b1	3.3	3.5	3.7
b2	19.7	20	20.3
b3	14.7	15	15.3
B	1	0.2	1.4
B1	1	1.3	1.6
c	1.3	1.6	1.9
c1	1.7	2	2.3
D	0.9	1	1.3
E	19.5	20	20.5
e	0.4	0.6	0.8
e1	-	0.6	-
L	4.6	4.8	5
L1	1.8	2	2.2
P	30°		
R	-	3.2	-
S	-	5.45	-
S1	-	1.41	-

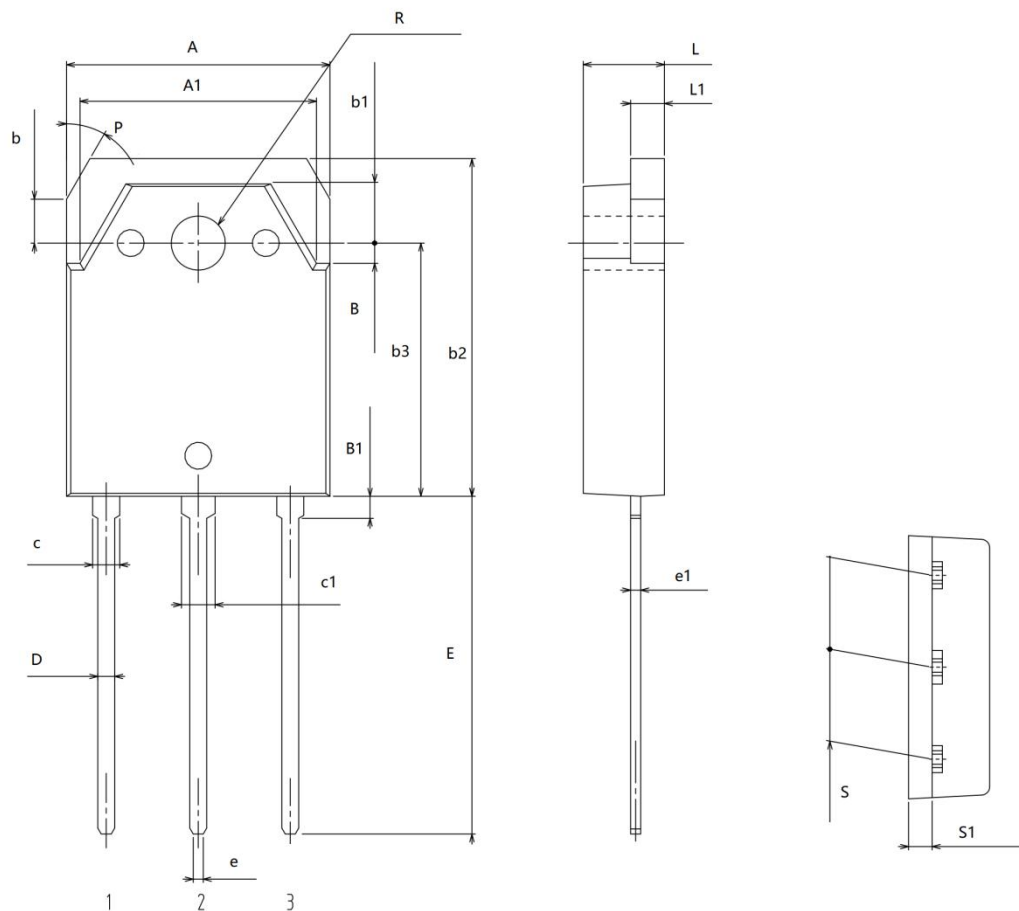

Package mechanical data

**TO-3PH mechanical data**

DIM.	mm.		
	min.	typ	max.
A	5.30		5.70
C	2.80		3.20
D	3.10		3.50
D1	1.80		2.20
E	0.80		1.10
F	0.65		0.95
F2	1.80		2.20
G	10.30		11.50
G1		5.45	
H	15.30		15.70
L	9.80	10	10.20
L2	22.80		23.20
L3	26.30		26.70
L4	43.20		44.40
L5	4.30		4.70
L6	24.30		24.70
L7	14.60		15
N	1.80		2.20
R	3.80		4.20
Dia	3.40		3.80

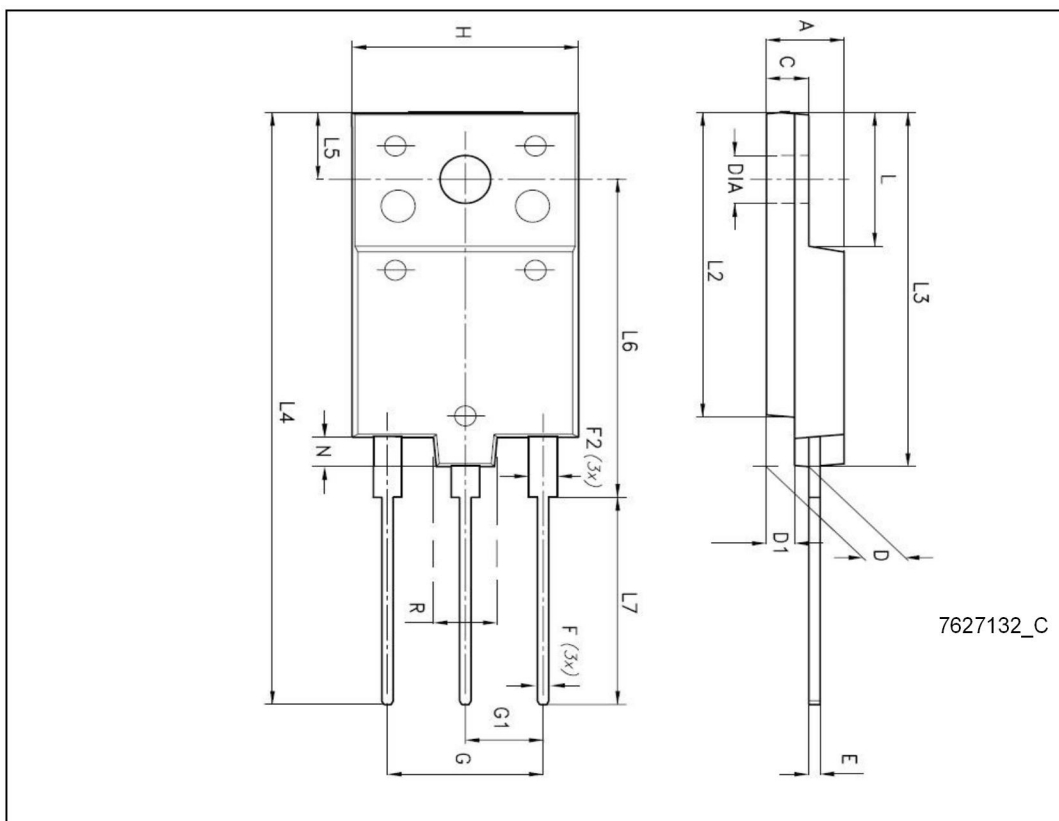

**TO-263 mechanical data**

DIM.	mm.		
	min.	typ	max.
A	9.65		10.29
C	14.6		15.88
D	0.51		0.92
D1	4.06		4.83
E	1.14		1.40
F	1.14		1.40
F2	8.64		9.64
G	2.29		2.79
G1	0.46		0.64
H		2.54BSC	

TO-263/D2PAK

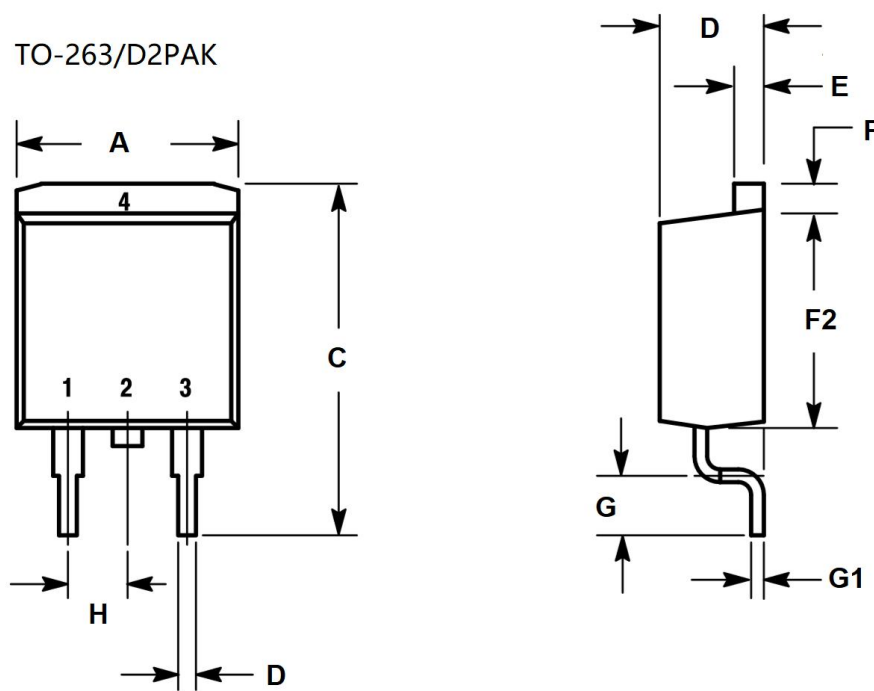

**TO-247 mechanical data**

DIM.	mm.		
	min.	typ	max.
A	4.7		5.31
A1	2.21		2.59
A2	1.5		2.49
b	1		1.4
b2	1.65		2.39
b4	2.59		3.43
c	0.38		0.89
D	20.8		21.46
D1	13.08		-
D2	0.51		1.35
E	15.49		16.26
E1	13.46		-
E2	4.32		5.49
e	5.46BSC		
L	19.81		20.32
L1	-		4.5
P	3.56		3.66
Q	5.38		6.2
S	6.15BSC		

